



BEACONS

7965 SERIES SAE Class I LED

The 7965 Series beacon combines all the major benefits of the latest LED technology with a traditional, strobe style housing at a price point comparable to a strobe. Available in either 5" or 7" height profiles, the 7965 is suitable for a wide range of applications where a high-intensity SAE Class I light is required. The 7965 features 12-24VDC operation and 11 flash patterns that produce an attention-getting warning signal. Each unit is backed by a 2-year warranty.



Video

To view a 7965 / 7970 Series product video, scan with any QR code reader app

Or visit [YouTube.com/ECCOSafety](https://www.youtube.com/ECCOSafety)

Models

PART NO.	VOLTAGE	AMPS	PROFILE	COLOR	MOUNT
7965X	12-24	3.6	5"	Choose	3 Bolt Flange/1" Pipe
7965X-VM	12-24	3.6	5"	Choose	Vacuum Magnet
7970X	12-24	3.6	7"	Choose	3 Bolt Flange/1" Pipe
7970X-VM	12-24	3.6	7"	Choose	Vacuum Magnet

Replace X in part number with desired color: A = amber, B = blue, C = clear, G = green, R = red

Features and Benefits

- 11 flash patterns
- Aluminum base, polycarbonate lens
- Switched cigarette plug adapter (vacuum-magnet models)
- Rechargeable battery powered model available in amber
- SAE J845 Class I (A & C only)
- SAE J845 Class II (B only)
- CE, R10
- Temperature Range: -22°F to +122°F (-30°C to +50°C)
- Warranty: 2 years

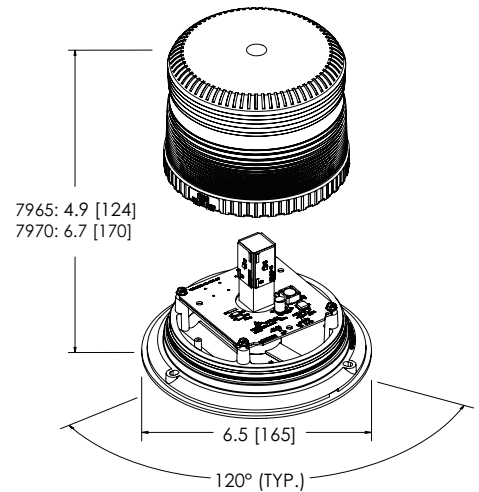

Parts & Accessories

- Lenses: 7965 - R6050LX
7970 - R6070LX

Replace X in part number with desired color:
A = amber, B = blue, C = clear, G = green, R = red